

MODEL :		TYPE
PROJECT :		
PREPARED BY :	DATE :	

SERIES SPECIFICATIONS

STRUT TO BEAM CLAMP NOTCHED TYPE



LINE DRAWING

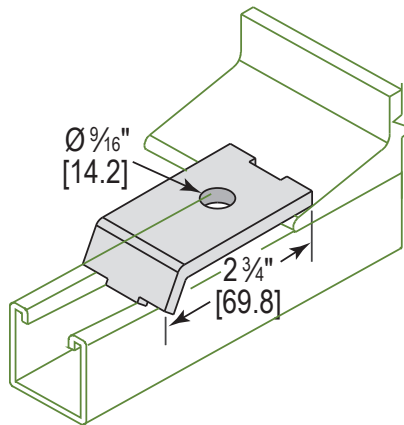

CONSTRUCTION

Finish
Electro-galvanized

Set Screw
-

Type
Notched

DIMENSION

Material Thickness (In.)
1/4"

Material Thickness (mm.)
6.3

Design Load (Lbs.)
1100

Design Load (kN)
4.89

Max Flange Thickness
-

Length
2 3/4"

APPLICATION AND PERFORMANCE SPECIFICATION INFORMATION IS SUBJECT TO CHANGE WITHOUT NOTIFICATION

MODEL :	TYPE
PROJECT :	
PREPARED BY :	DATE :

DIMENSION (Cont.)

Hole Opening
9/16"

ORDERING INFORMATION

Part Number: STBNT

Weight (lbs.): 0.29

IMS Code: 0304-8318

APPLICATION AND PERFORMANCE SPECIFICATION INFORMATION IS SUBJECT TO CHANGE WITHOUT NOTIFICATION