

MODEL :		TYPE
PROJECT :		
PREPARED BY :	DATE :	

## SERIES SPECIFICATIONS

WIDE MOUTH MLB IRON UNV BEAM CLAMP 3/8"-16  
EG



## LINE DRAWING

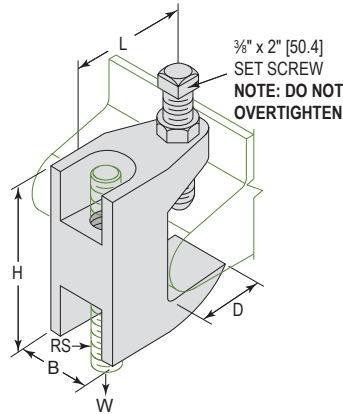

## CONSTRUCTION

Finish  
Electro-galvanized

Type  
Wide Mouth Universal

## DIMENSION

Set Screw  
3/8" x 2"

Max Flange Thickness  
1 1/16"

Rod Size (RS)  
3/8" - 16

Max Load W (Lbs.)  
400

Max Load W (kN)  
1.78

Max Pipe Size (In.)  
4

Max Pipe Size (mm.)  
100

Width (In.)  
7/8"

APPLICATION AND PERFORMANCE SPECIFICATION INFORMATION IS SUBJECT TO CHANGE WITHOUT NOTIFICATION

MODEL :		TYPE
PROJECT :		
PREPARED BY :	DATE :	

### DIMENSION (Cont.)

Width (mm.)  
22.2

Beam Length (In.)  
1-3/8"

Beam Length (mm.)  
34.9

Height (In.)  
2"

Height (mm.)  
50.8

Clamp Depth (In.)  
1/2"

Clamp Depth (mm.)  
12.7

### ORDERING INFORMATION

Part Number: BCUM037EG

Weight (lbs.): 0.41

IMS Code: 0304-8327

APPLICATION AND PERFORMANCE SPECIFICATION INFORMATION IS SUBJECT TO CHANGE WITHOUT NOTIFICATION