

MODEL :		TYPE
PROJECT :		
PREPARED BY :	DATE :	

SERIES SPECIFICATIONS

MLB IRON ROD SPRT BEAM CLAMP 1/4"-20

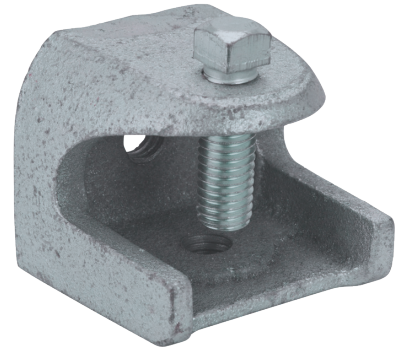

LINE DRAWING

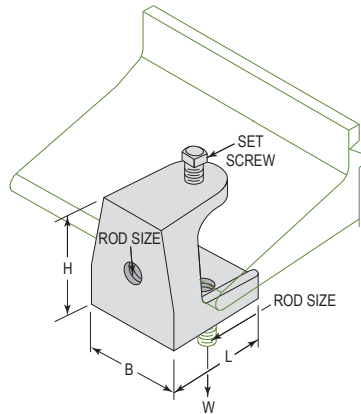

CONSTRUCTION

Finish
Electro-galvanized

DIMENSION

Set Screw
5/16"-18

Rod Size (RS)
1/4"-20

Max Load W (kN)
1.49

Max Load W (Lbs.)
335

Width (In.)
13/16"

Width (mm.)
30.2

Length (In.)
1-3/8"

Length (mm.)
34.9

APPLICATION AND PERFORMANCE SPECIFICATION INFORMATION IS SUBJECT TO CHANGE WITHOUT NOTIFICATION

MODEL :		TYPE
PROJECT :		
PREPARED BY :	DATE :	

DIMENSION (Cont.)

Height (mm.)
34.9

Height (In.)
1-3/8"

ORDERING INFORMATION

Part Number: BCRS025EG

Weight (lbs.): 0.16

IMS Code: 0304-8330

APPLICATION AND PERFORMANCE SPECIFICATION INFORMATION IS SUBJECT TO CHANGE WITHOUT NOTIFICATION