

MODEL :		TYPE
PROJECT :		
PREPARED BY :	DATE :	

## SERIES SPECIFICATIONS

MLB IRON ROD SPRT BEAM CLAMP 3/8"-16

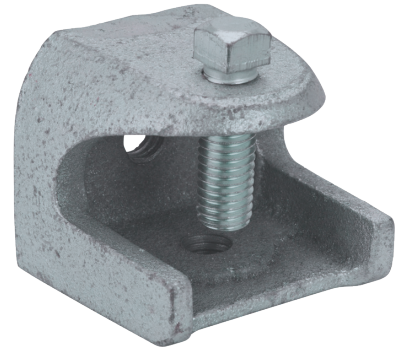

## LINE DRAWING

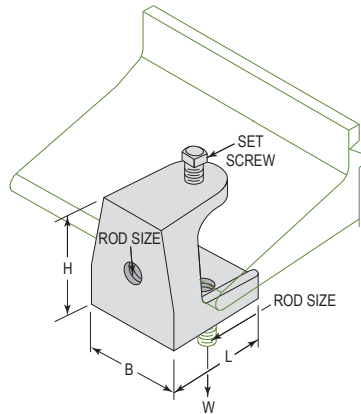

## CONSTRUCTION

Finish  
Electro-galvanized

## DIMENSION

Set Screw 1/2"-13	Rod Size (RS) 3/8"-16
Max Load W (kN) 2.34	Max Load W (Lbs.) 525
Width (In.) 2-1/16"	Width (mm.) 52.4
Length (In.) 1-7/8"	Length (mm.) 47.6

APPLICATION AND PERFORMANCE SPECIFICATION INFORMATION IS SUBJECT TO CHANGE WITHOUT NOTIFICATION

MODEL :		TYPE
PROJECT :		
PREPARED BY :	DATE :	

### DIMENSION (Cont.)

Height (mm.)  
44.4

Height (In.)  
1-3/4"

### ORDERING INFORMATION

Part Number: BCRS037EG

Weight (lbs.): 0.09

IMS Code: 0304-8333

APPLICATION AND PERFORMANCE SPECIFICATION INFORMATION IS SUBJECT TO CHANGE WITHOUT NOTIFICATION