

MODEL :		TYPE
PROJECT :		
PREPARED BY :	DATE :	

SERIES SPECIFICATIONS

MLB IRON ROD SPRT BEAM CLAMP 1/2"-13

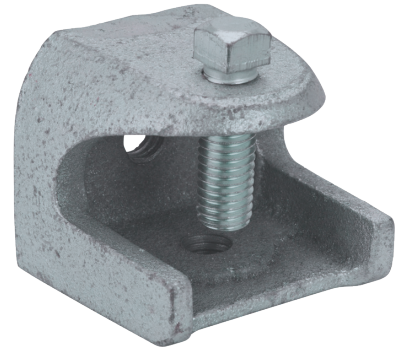

LINE DRAWING

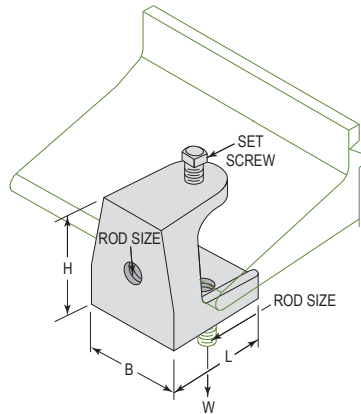

CONSTRUCTION

Finish
Electro-galvanized

DIMENSION

Set Screw
1/2"-13

Rod Size (RS)
1/2"-13

Max Load W (kN)
3.34

Max Load W (Lbs.)
750

Width (In.)
2-1/2"

Width (mm.)
63.5

Length (In.)
2-3/8"

Length (mm.)
60.3

APPLICATION AND PERFORMANCE SPECIFICATION INFORMATION IS SUBJECT TO CHANGE WITHOUT NOTIFICATION

MODEL :		TYPE
PROJECT :		
PREPARED BY :	DATE :	

DIMENSION (Cont.)

Height (mm.)
55.6

Height (In.)
2-3/16"

ORDERING INFORMATION

Part Number: BCRS050EG

Weight (lbs.): 1.5

IMS Code: 0304-8336

APPLICATION AND PERFORMANCE SPECIFICATION INFORMATION IS SUBJECT TO CHANGE WITHOUT NOTIFICATION