

MODEL :		TYPE
PROJECT :		
PREPARED BY :	DATE :	

SERIES SPECIFICATIONS

HINGED FLR FXT HANGER 1-5/8" CHAN 9/16" HOLE



LINE DRAWING

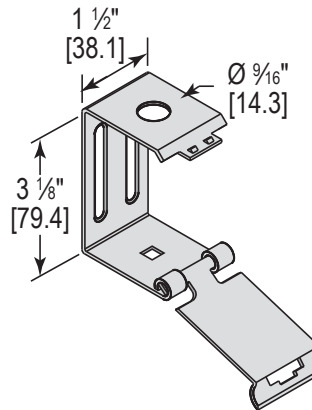

CONSTRUCTION

Channel
1 5/8"

DIMENSION

Max Load (W) (kN)
0.53

Max Load (W) (Lbs.)
120

Width (In.)
1 1/2"

Hole Diameter
9/16"

Height (mm.)
3 1/8"

APPLICATION AND PERFORMANCE SPECIFICATION INFORMATION IS SUBJECT TO CHANGE WITHOUT NOTIFICATION

MODEL :		TYPE
PROJECT :		
PREPARED BY :	DATE :	

ORDERING INFORMATION

Part Number: HFH10

Weight (lbs.): 0.35

IMS Code: 0304-8471

APPLICATION AND PERFORMANCE SPECIFICATION INFORMATION IS SUBJECT TO CHANGE WITHOUT NOTIFICATION