

MODEL :		TYPE
PROJECT :		
PREPARED BY :	DATE :	

## SERIES SPECIFICATIONS

NOTCHED SQ. WASHER 1/2"



## LINE DRAWING

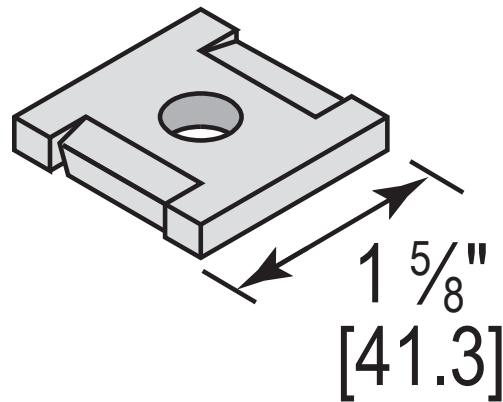

## CONSTRUCTION

Finish  
Electro-galvanized

## DIMENSION

Bolt Size (In.)  
1/2"

Bolt Size (mm.)  
12

Length (In.)  
1-5/8"

Thickness (mm.)  
1/4"

APPLICATION AND PERFORMANCE SPECIFICATION INFORMATION IS SUBJECT TO CHANGE WITHOUT NOTIFICATION

MODEL :		TYPE
PROJECT :		
PREPARED BY :	DATE :	

ORDERING INFORMATION

Part Number: NSW50EG

Weight (lbs.): 0.16

IMS Code: 0304-8507

APPLICATION AND PERFORMANCE SPECIFICATION INFORMATION IS SUBJECT TO CHANGE WITHOUT NOTIFICATION