

MODEL :		TYPE
PROJECT :		
PREPARED BY :	DATE :	

SERIES SPECIFICATIONS

2 HOLE ADJ GUSSET CORNER ANGLE



LINE DRAWING

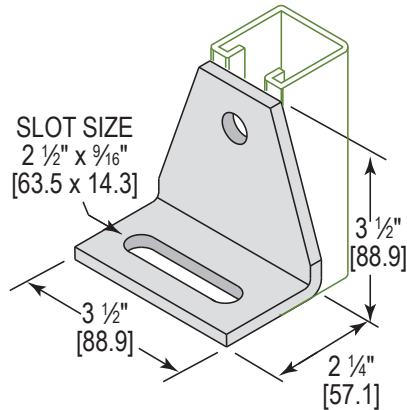

CONSTRUCTION

Type
Adjustable Gusset

Finish
Electro-Galvanized

of Holes
2

DIMENSION

Width (In.)
3 1/2"

Slot Size
2 1/2" x 9/16"

Length (In.)
2 1/4"

Thickness (mm.)
1/4"

APPLICATION AND PERFORMANCE SPECIFICATION INFORMATION IS SUBJECT TO CHANGE WITHOUT NOTIFICATION

MODEL :		TYPE
PROJECT :		
PREPARED BY :	DATE :	

ORDERING INFORMATION

Part Number: AF24

Weight (lbs.): 0.87

IMS Code: 0304-8588

APPLICATION AND PERFORMANCE SPECIFICATION INFORMATION IS SUBJECT TO CHANGE WITHOUT NOTIFICATION