

MODEL :		TYPE
PROJECT :		
PREPARED BY :	DATE :	

SERIES SPECIFICATIONS

PIPE STRAP 1/2"



LINE DRAWING

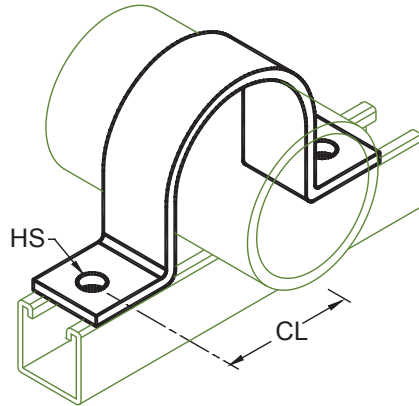

CONSTRUCTION

Finish
Electro-galvanized

DIMENSION

Pipe Size (In.)
1/2"

Pipe Size (mm.)
15

CL (In.)
1-1/8"

CL (mm.)
23.8

HS (In.)
5/16"

HS (mm.)
7.9

APPLICATION AND PERFORMANCE SPECIFICATION INFORMATION IS SUBJECT TO CHANGE WITHOUT NOTIFICATION

MODEL :	TYPE
PROJECT :	
PREPARED BY :	DATE :

ORDERING INFORMATION

Part Number: PS050EG

Weight (lbs.): 0.23

IMS Code: 0304-8681

APPLICATION AND PERFORMANCE SPECIFICATION INFORMATION IS SUBJECT TO CHANGE WITHOUT NOTIFICATION

MODEL :		TYPE
PROJECT :		
PREPARED BY :	DATE :	

SERIES SPECIFICATIONS

PIPE STRAP 3/4"



LINE DRAWING

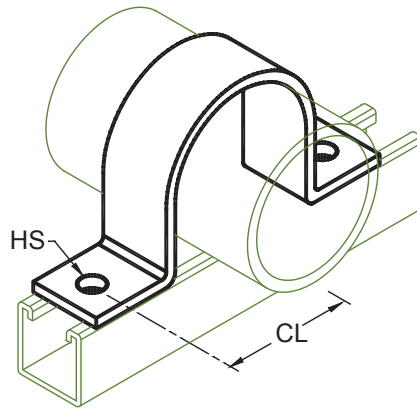

CONSTRUCTION

Finish
Electro-galvanized

DIMENSION

Pipe Size (In.)
3/4"

Pipe Size (mm.)
20

CL (In.)
1-3/16"

CL (mm.)
25.4

HS (In.)
5/16"

HS (mm.)
7.9

APPLICATION AND PERFORMANCE SPECIFICATION INFORMATION IS SUBJECT TO CHANGE WITHOUT NOTIFICATION

MODEL :		TYPE
PROJECT :		
PREPARED BY :	DATE :	

ORDERING INFORMATION

Part Number: PS075EG

Weight (lbs.): 0.26

IMS Code: 0304-8684

APPLICATION AND PERFORMANCE SPECIFICATION INFORMATION IS SUBJECT TO CHANGE WITHOUT NOTIFICATION

MODEL :		TYPE
PROJECT :		
PREPARED BY :	DATE :	

SERIES SPECIFICATIONS

PIPE STRAP 1"



LINE DRAWING

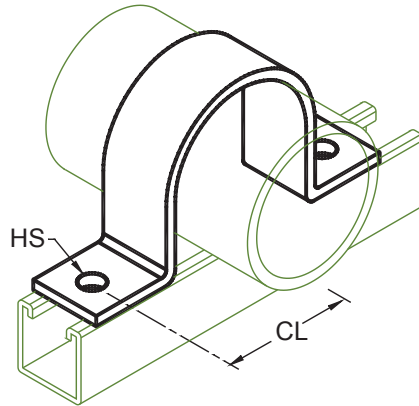

CONSTRUCTION

Finish
Electro-galvanized

DIMENSION

Pipe Size (In.)
1"

Pipe Size (mm.)
25

CL (In.)
1-5/16"

CL (mm.)
28.6

HS (In.)
5/16"

HS (mm.)
7.9

APPLICATION AND PERFORMANCE SPECIFICATION INFORMATION IS SUBJECT TO CHANGE WITHOUT NOTIFICATION

MODEL :		TYPE
PROJECT :		
PREPARED BY :	DATE :	

ORDERING INFORMATION

Part Number: PS100EG

Weight (lbs.): 0.29

IMS Code: 0304-8687

APPLICATION AND PERFORMANCE SPECIFICATION INFORMATION IS SUBJECT TO CHANGE WITHOUT NOTIFICATION

MODEL :		TYPE
PROJECT :		
PREPARED BY :	DATE :	

SERIES SPECIFICATIONS

PIPE STRAP 1-1/4"



LINE DRAWING

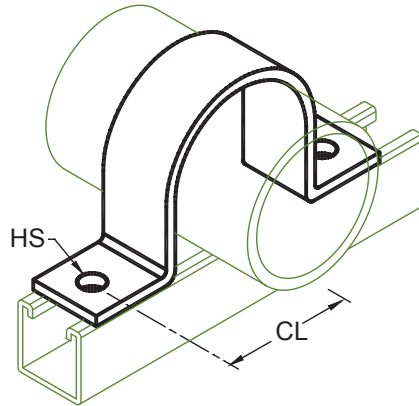

CONSTRUCTION

Finish
Electro-galvanized

DIMENSION

Pipe Size (In.)
1-1/4"

Pipe Size (mm.)
32

CL (In.)
1-7/16"

CL (mm.)
33.3

HS (In.)
5/16"

HS (mm.)
7.9

APPLICATION AND PERFORMANCE SPECIFICATION INFORMATION IS SUBJECT TO CHANGE WITHOUT NOTIFICATION

MODEL :		TYPE
PROJECT :		
PREPARED BY :	DATE :	

ORDERING INFORMATION

Part Number: PS125EG

Weight (lbs.): 0.34

IMS Code: 0304-8690

APPLICATION AND PERFORMANCE SPECIFICATION INFORMATION IS SUBJECT TO CHANGE WITHOUT NOTIFICATION

MODEL :		TYPE
PROJECT :		
PREPARED BY :	DATE :	

SERIES SPECIFICATIONS

PIPE STRAP 1-1/2"



LINE DRAWING

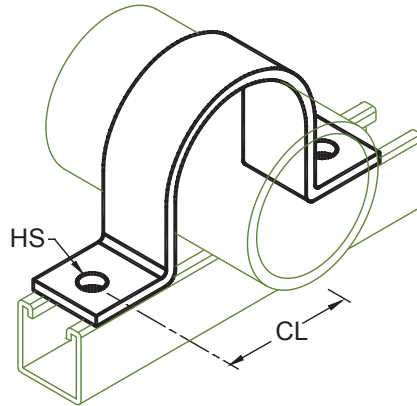

CONSTRUCTION

Finish
Electro-galvanized

DIMENSION

Pipe Size (In.)
1-1/2"

Pipe Size (mm.)
40

CL (In.)
1-9/16"

CL (mm.)
36.5

HS (In.)
5/16"

HS (mm.)
7.9

APPLICATION AND PERFORMANCE SPECIFICATION INFORMATION IS SUBJECT TO CHANGE WITHOUT NOTIFICATION

MODEL :		TYPE
PROJECT :		
PREPARED BY :	DATE :	

ORDERING INFORMATION

Part Number: PS150EG

Weight (lbs.): 0.37

IMS Code: 0304-8693

APPLICATION AND PERFORMANCE SPECIFICATION INFORMATION IS SUBJECT TO CHANGE WITHOUT NOTIFICATION

MODEL :		TYPE
PROJECT :		
PREPARED BY :	DATE :	

SERIES SPECIFICATIONS

PIPE STRAP 2"



LINE DRAWING

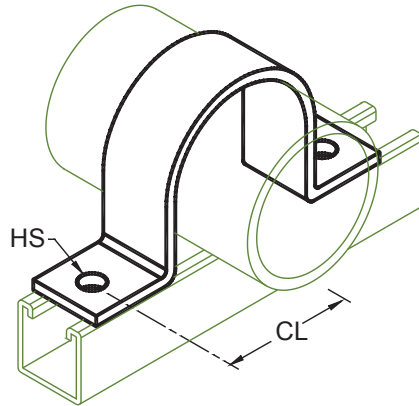

CONSTRUCTION

Finish
Electro-galvanized

DIMENSION

Pipe Size (In.)
2"

Pipe Size (mm.)
50

CL (In.)
2-1/8"

CL (mm.)
54

HS (In.)
7/16"

HS (mm.)
11.1

APPLICATION AND PERFORMANCE SPECIFICATION INFORMATION IS SUBJECT TO CHANGE WITHOUT NOTIFICATION

MODEL :		TYPE
PROJECT :		
PREPARED BY :	DATE :	

ORDERING INFORMATION

Part Number: PS200EG

Weight (lbs.): 0.92

IMS Code: 0304-8696

APPLICATION AND PERFORMANCE SPECIFICATION INFORMATION IS SUBJECT TO CHANGE WITHOUT NOTIFICATION

MODEL :		TYPE
PROJECT :		
PREPARED BY :	DATE :	

SERIES SPECIFICATIONS

PIPE STRAP 2-1/2"



LINE DRAWING

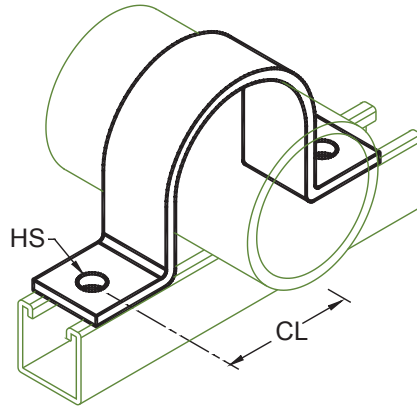

CONSTRUCTION

Finish
Electro-galvanized

DIMENSION

Pipe Size (In.)
2-1/2"

Pipe Size (mm.)
65

CL (In.)
2-3/8"

CL (mm.)
60.3

HS (In.)
7/16"

HS (mm.)
11.1

APPLICATION AND PERFORMANCE SPECIFICATION INFORMATION IS SUBJECT TO CHANGE WITHOUT NOTIFICATION

MODEL :	TYPE
PROJECT :	
PREPARED BY :	DATE :

ORDERING INFORMATION

Part Number: PS250EG

Weight (lbs.): 1.08

IMS Code: 0304-8699

APPLICATION AND PERFORMANCE SPECIFICATION INFORMATION IS SUBJECT TO CHANGE WITHOUT NOTIFICATION

MODEL :		TYPE
PROJECT :		
PREPARED BY :	DATE :	

SERIES SPECIFICATIONS

PIPE STRAP 3"



LINE DRAWING

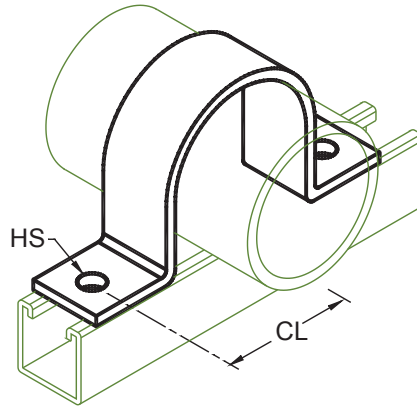

CONSTRUCTION

Finish
Electro-galvanized

DIMENSION

Pipe Size (In.)
3"

Pipe Size (mm.)
80

CL (In.)
2-11/16"

CL (mm.)
68.3

HS (In.)
7/16"

HS (mm.)
11.1

APPLICATION AND PERFORMANCE SPECIFICATION INFORMATION IS SUBJECT TO CHANGE WITHOUT NOTIFICATION

MODEL :		TYPE
PROJECT :		
PREPARED BY :	DATE :	

ORDERING INFORMATION

Part Number: PS300EG

Weight (lbs.): 1.33

IMS Code: 0304-8702

APPLICATION AND PERFORMANCE SPECIFICATION INFORMATION IS SUBJECT TO CHANGE WITHOUT NOTIFICATION

MODEL :		TYPE
PROJECT :		
PREPARED BY :	DATE :	

SERIES SPECIFICATIONS

PIPE STRAP 5"



LINE DRAWING

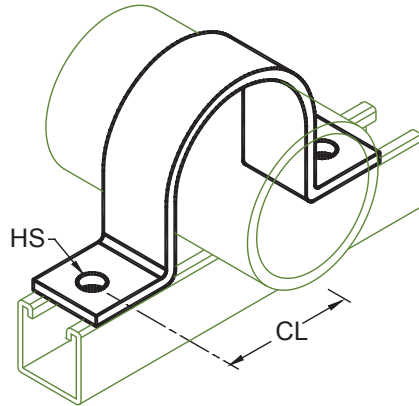

CONSTRUCTION

Finish
Electro-galvanized

DIMENSION

Pipe Size (In.)
5"

Pipe Size (mm.)
125

CL (In.)
3-3/4"

CL (mm.)
95.2

HS (In.)
9/16"

HS (mm.)
14.2

APPLICATION AND PERFORMANCE SPECIFICATION INFORMATION IS SUBJECT TO CHANGE WITHOUT NOTIFICATION

MODEL :		TYPE
PROJECT :		
PREPARED BY :	DATE :	

ORDERING INFORMATION

Part Number: PS500EG

Weight (lbs.): 1.95

IMS Code: 0304-8705

APPLICATION AND PERFORMANCE SPECIFICATION INFORMATION IS SUBJECT TO CHANGE WITHOUT NOTIFICATION

MODEL :		TYPE
PROJECT :		
PREPARED BY :	DATE :	

SERIES SPECIFICATIONS

PIPE STRAP 6"



LINE DRAWING

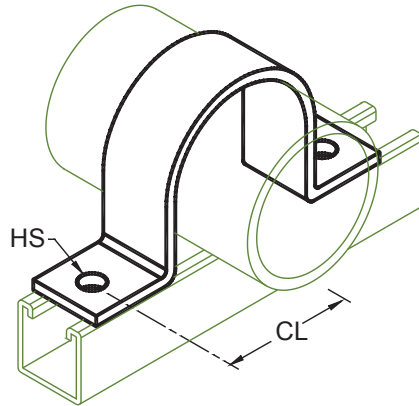

CONSTRUCTION

Finish
Electro-galvanized

DIMENSION

Pipe Size (In.)
6"

Pipe Size (mm.)
150

CL (In.)
4-1/4"

CL (mm.)
107.9

HS (In.)
9/16"

HS (mm.)
14.2

APPLICATION AND PERFORMANCE SPECIFICATION INFORMATION IS SUBJECT TO CHANGE WITHOUT NOTIFICATION

MODEL :	TYPE
PROJECT :	
PREPARED BY :	DATE :

ORDERING INFORMATION

Part Number: PS600EG

Weight (lbs.): 2.27

IMS Code: 0304-8708

APPLICATION AND PERFORMANCE SPECIFICATION INFORMATION IS SUBJECT TO CHANGE WITHOUT NOTIFICATION