

MODEL :		TYPE
PROJECT :		
PREPARED BY :	DATE :	

SERIES SPECIFICATIONS

PIPE STRAP 3/4"



LINE DRAWING

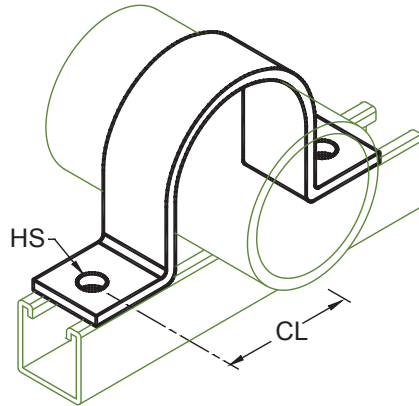

CONSTRUCTION

Finish
Electro-galvanized

DIMENSION

Pipe Size (In.)
3/4"

Pipe Size (mm.)
20

CL (In.)
1-3/16"

CL (mm.)
25.4

HS (In.)
5/16"

HS (mm.)
7.9

APPLICATION AND PERFORMANCE SPECIFICATION INFORMATION IS SUBJECT TO CHANGE WITHOUT NOTIFICATION

MODEL :		TYPE
PROJECT :		
PREPARED BY :	DATE :	

ORDERING INFORMATION

Part Number: PS075EG

Weight (lbs.): 0.26

IMS Code: 0304-8684

APPLICATION AND PERFORMANCE SPECIFICATION INFORMATION IS SUBJECT TO CHANGE WITHOUT NOTIFICATION