

MODEL :		TYPE
PROJECT :		
PREPARED BY :	DATE :	

## SERIES SPECIFICATIONS

PIPE STRAP 2"



## LINE DRAWING

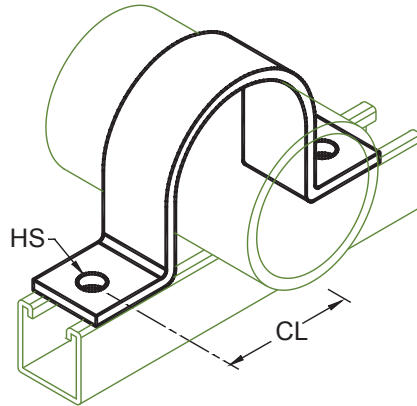

## CONSTRUCTION

Finish  
Electro-galvanized

## DIMENSION

Pipe Size (In.)  
2"

Pipe Size (mm.)  
50

CL (In.)  
2-1/8"

CL (mm.)  
54

HS (In.)  
7/16"

HS (mm.)  
11.1

APPLICATION AND PERFORMANCE SPECIFICATION INFORMATION IS SUBJECT TO CHANGE WITHOUT NOTIFICATION

MODEL :		TYPE
PROJECT :		
PREPARED BY :	DATE :	

ORDERING INFORMATION

Part Number: PS200EG

Weight (lbs.): 0.92

IMS Code: 0304-8696

APPLICATION AND PERFORMANCE SPECIFICATION INFORMATION IS SUBJECT TO CHANGE WITHOUT NOTIFICATION