

MODEL :		TYPE
PROJECT :		
PREPARED BY :	DATE :	

SERIES SPECIFICATIONS

PIPE STRAP 2-1/2"



LINE DRAWING

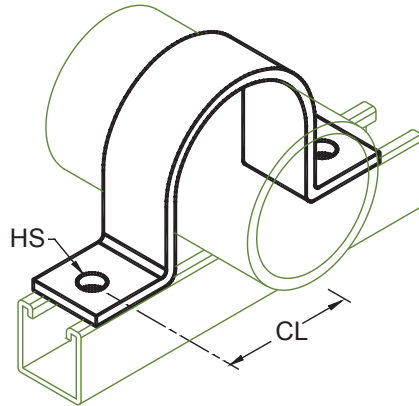

CONSTRUCTION

Finish
Electro-galvanized

DIMENSION

Pipe Size (In.)
2-1/2"

Pipe Size (mm.)
65

CL (In.)
2-3/8"

CL (mm.)
60.3

HS (In.)
7/16"

HS (mm.)
11.1

APPLICATION AND PERFORMANCE SPECIFICATION INFORMATION IS SUBJECT TO CHANGE WITHOUT NOTIFICATION

MODEL :		TYPE
PROJECT :		
PREPARED BY :	DATE :	

ORDERING INFORMATION

Part Number: PS250EG

Weight (lbs.): 1.08

IMS Code: 0304-8699

APPLICATION AND PERFORMANCE SPECIFICATION INFORMATION IS SUBJECT TO CHANGE WITHOUT NOTIFICATION