

MODEL :		TYPE
PROJECT :		
PREPARED BY :	DATE :	

SERIES SPECIFICATIONS

PIPE STRAP 5"



LINE DRAWING

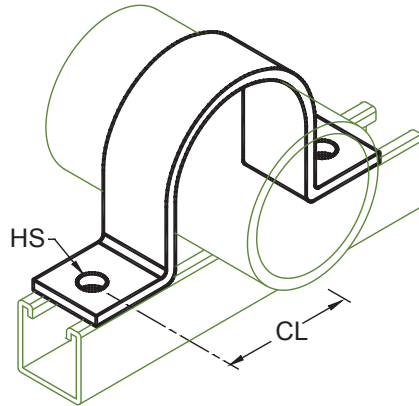

CONSTRUCTION

Finish
Electro-galvanized

DIMENSION

Pipe Size (In.)
5"

Pipe Size (mm.)
125

CL (In.)
3-3/4"

CL (mm.)
95.2

HS (In.)
9/16"

HS (mm.)
14.2

APPLICATION AND PERFORMANCE SPECIFICATION INFORMATION IS SUBJECT TO CHANGE WITHOUT NOTIFICATION

MODEL :		TYPE
PROJECT :		
PREPARED BY :	DATE :	

ORDERING INFORMATION

Part Number: PS500EG

Weight (lbs.): 1.95

IMS Code: 0304-8705

APPLICATION AND PERFORMANCE SPECIFICATION INFORMATION IS SUBJECT TO CHANGE WITHOUT NOTIFICATION