

MODEL :		TYPE
PROJECT :		
PREPARED BY :	DATE :	

## SERIES SPECIFICATIONS

PIPE STRAP 6"



## LINE DRAWING

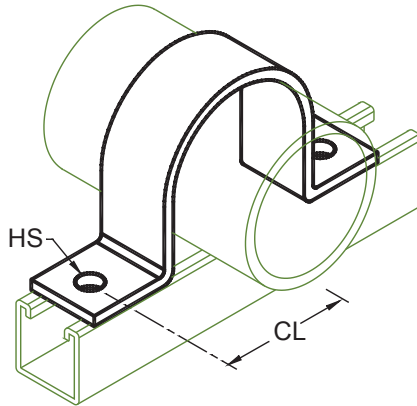

## CONSTRUCTION

Finish  
Electro-galvanized

## DIMENSION

Pipe Size (In.)  
6"

Pipe Size (mm.)  
150

CL (In.)  
4-1/4"

CL (mm.)  
107.9

HS (In.)  
9/16"

HS (mm.)  
14.2

APPLICATION AND PERFORMANCE SPECIFICATION INFORMATION IS SUBJECT TO CHANGE WITHOUT NOTIFICATION

MODEL :	TYPE	
PROJECT :		
PREPARED BY :	DATE :	

ORDERING INFORMATION

Part Number: PS600EG

Weight (lbs.): 2.27

IMS Code: 0304-8708

APPLICATION AND PERFORMANCE SPECIFICATION INFORMATION IS SUBJECT TO CHANGE WITHOUT NOTIFICATION