

MODEL :		TYPE
PROJECT :		
PREPARED BY :	DATE :	

## SERIES SPECIFICATIONS

EMT STRUT CLAMP 1/2"



## LINE DRAWING

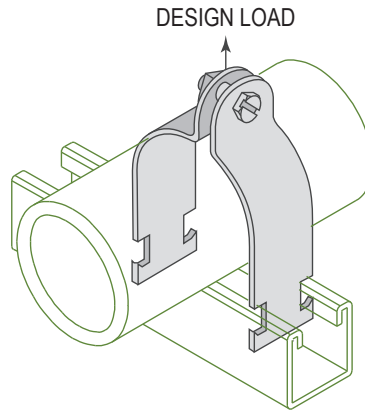

## CONSTRUCTION

Type  
EMT

Design Load (Lbs.)  
400

Design Load - kN  
1.78

Finish  
Electro-Galvanized

## DIMENSION

Size (In.)  
1/2"

Size (mm.)  
15

O.D. (In.)  
0.706

O.D. (mm.)  
17.9

APPLICATION AND PERFORMANCE SPECIFICATION INFORMATION IS SUBJECT TO CHANGE WITHOUT NOTIFICATION

MODEL :	TYPE
PROJECT :	
PREPARED BY :	DATE :

ORDERING INFORMATION

Part Number: ESC050EG

Weight (lbs.): 0.1

IMS Code: 0304-8735

APPLICATION AND PERFORMANCE SPECIFICATION INFORMATION IS SUBJECT TO CHANGE WITHOUT NOTIFICATION