

MODEL :		TYPE
PROJECT :		
PREPARED BY :	DATE :	

SERIES SPECIFICATIONS

EMT STRUT CLAMP 3/4"



LINE DRAWING

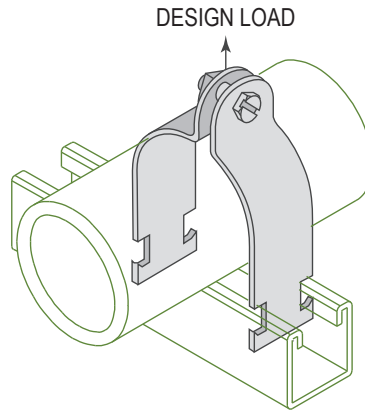

CONSTRUCTION

Type
EMT

Design Load (Lbs.)
400

Design Load - kN
1.78

Finish
Electro-Galvanized

DIMENSION

Size (In.)
3/4"

Size (mm.)
20

O.D. (In.)
0.922

O.D. (mm.)
23.4

APPLICATION AND PERFORMANCE SPECIFICATION INFORMATION IS SUBJECT TO CHANGE WITHOUT NOTIFICATION

MODEL :		TYPE
PROJECT :		
PREPARED BY :	DATE :	

ORDERING INFORMATION

Part Number: ESC075EG

Weight (lbs.): 0.11

IMS Code: 0304-8738

APPLICATION AND PERFORMANCE SPECIFICATION INFORMATION IS SUBJECT TO CHANGE WITHOUT NOTIFICATION