

MODEL :		TYPE
PROJECT :		
PREPARED BY :	DATE :	

SERIES SPECIFICATIONS

EMT STRUT CLAMP 1-1/4"



LINE DRAWING

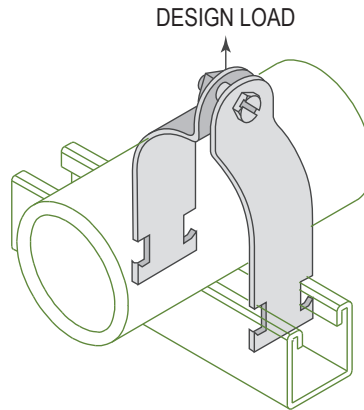

CONSTRUCTION

Type
EMT

Design Load (Lbs.)
600

Design Load - kN
2.67

Finish
Electro-Galvanized

DIMENSION

Size (In.)
1-1/4"

Size (mm.)
32

O.D. (In.)
1.51

O.D. (mm.)
38.4

APPLICATION AND PERFORMANCE SPECIFICATION INFORMATION IS SUBJECT TO CHANGE WITHOUT NOTIFICATION

MODEL :		TYPE
PROJECT :		
PREPARED BY :		DATE :

ORDERING INFORMATION

Part Number: ESC125EG

Weight (lbs.): 0.16

IMS Code: 0304-8744

APPLICATION AND PERFORMANCE SPECIFICATION INFORMATION IS SUBJECT TO CHANGE WITHOUT NOTIFICATION