

MODEL :		TYPE
PROJECT :		
PREPARED BY :	DATE :	

SERIES SPECIFICATIONS

EMT STRUT CLAMP 1-1/2"



LINE DRAWING

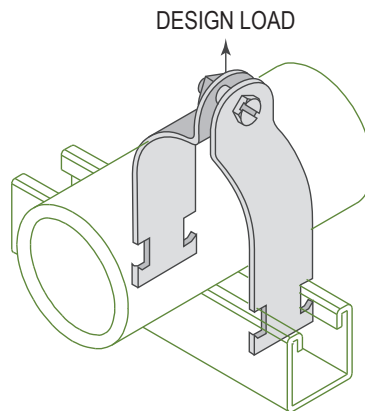

CONSTRUCTION

Type
EMT

Design Load (Lbs.)
800

Design Load - kN
3.56

Finish
Electro-Galvanized

DIMENSION

Size (In.)
1-1/2"

Size (mm.)
40

O.D. (In.)
1.74

O.D. (mm.)
44.2

APPLICATION AND PERFORMANCE SPECIFICATION INFORMATION IS SUBJECT TO CHANGE WITHOUT NOTIFICATION

MODEL :		TYPE
PROJECT :		
PREPARED BY :	DATE :	

ORDERING INFORMATION

Part Number: ESC150EG

Weight (lbs.): 0.26

IMS Code: 0304-8747

APPLICATION AND PERFORMANCE SPECIFICATION INFORMATION IS SUBJECT TO CHANGE WITHOUT NOTIFICATION