

MODEL :		TYPE
PROJECT :		
PREPARED BY :	DATE :	

SERIES SPECIFICATIONS

1 PC UNV STRUT CLAMP 1"



LINE DRAWING

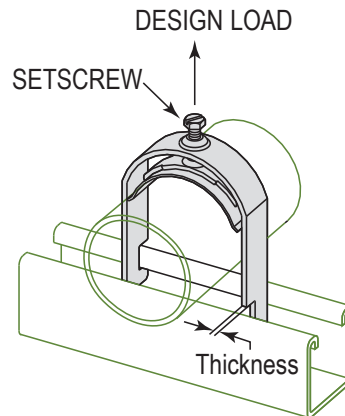

CONSTRUCTION

Type
One Piece Universal

Design Load (Lbs.)
300

Design Load - kN
1.36

Finish
Electro-galvanized

DIMENSION

EMT Size (In.)
1"

EMT Size (mm.)
25

Thickness (ga.)
14 Ga.

Thickness (mm.)
1.9

Rigid Conduit Size (In.)
3/4"

Rigid Conduit Size (mm.)
20

APPLICATION AND PERFORMANCE SPECIFICATION INFORMATION IS SUBJECT TO CHANGE WITHOUT NOTIFICATION

MODEL :	TYPE	
PROJECT :		
PREPARED BY :	DATE :	

ORDERING INFORMATION

Part Number: OPUSC100EG

Weight (lbs.): 11

IMS Code: 0304-8762

APPLICATION AND PERFORMANCE SPECIFICATION INFORMATION IS SUBJECT TO CHANGE WITHOUT NOTIFICATION