

MODEL :		TYPE
PROJECT :		
PREPARED BY :	DATE :	

SERIES SPECIFICATIONS

1 PC UNV STRUT CLAMP 3"



LINE DRAWING

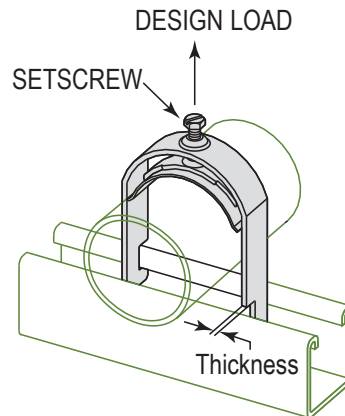

CONSTRUCTION

Type
One Piece Universal

Design Load (Lbs.)
400

Design Load - kN
1.78

Finish
Electro-galvanized

DIMENSION

EMT Size (In.)
3"

EMT Size (mm.)
80

Thickness (ga.)
12 Ga.

Thickness (mm.)
2.6

Rigid Conduit Size (In.)
3"

Rigid Conduit Size (mm.)
80

APPLICATION AND PERFORMANCE SPECIFICATION INFORMATION IS SUBJECT TO CHANGE WITHOUT NOTIFICATION

MODEL :	TYPE	
PROJECT :		
PREPARED BY :	DATE :	

ORDERING INFORMATION

Part Number: OPUSC300EG

Weight (lbs.): 30.2

IMS Code: 0304-8780

APPLICATION AND PERFORMANCE SPECIFICATION INFORMATION IS SUBJECT TO CHANGE WITHOUT NOTIFICATION