

|               |        |      |
|---------------|--------|------|
| MODEL :       |        | TYPE |
| PROJECT :     |        |      |
| PREPARED BY : | DATE : |      |

## SERIES SPECIFICATIONS

1 PC UNV STRUT CLAMP 4"

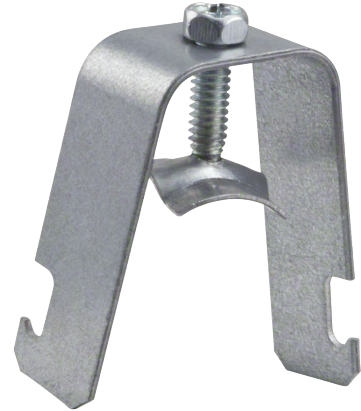

## LINE DRAWING

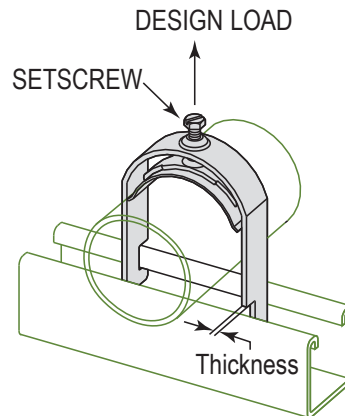

## CONSTRUCTION

Type  
One Piece Universal

Design Load (Lbs.)  
400

Design Load - kN  
1.78

Finish  
Electro-galvanized

## DIMENSION

EMT Size (In.)  
4"

EMT Size (mm.)  
100

Thickness (ga.)  
12 Ga.

Thickness (mm.)  
2.6

Rigid Conduit Size (In.)  
4"

Rigid Conduit Size (mm.)  
100

APPLICATION AND PERFORMANCE SPECIFICATION INFORMATION IS SUBJECT TO CHANGE WITHOUT NOTIFICATION

|               |        |      |
|---------------|--------|------|
| MODEL :       |        | TYPE |
| PROJECT :     |        |      |
| PREPARED BY : | DATE : |      |

ORDERING INFORMATION

Part Number: OPUSC400EG

Weight (lbs.): 36.6

IMS Code: 0304-8786

APPLICATION AND PERFORMANCE SPECIFICATION INFORMATION IS SUBJECT TO CHANGE WITHOUT NOTIFICATION