

MODEL :		TYPE
PROJECT :		
PREPARED BY :	DATE :	

SERIES SPECIFICATIONS

RIGID STRUT CLAMP 3/8"



LINE DRAWING

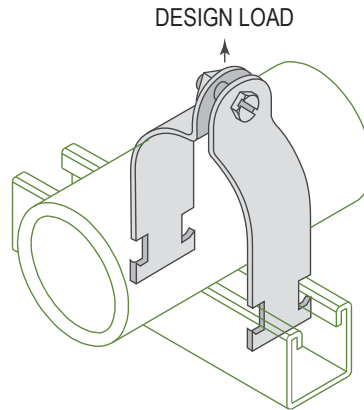

CONSTRUCTION

Type
Rigid

Design Load (Lbs.)
400

Design Load - kN
1.78

Finish
Electro-Galvanized

DIMENSION

Size (In.)
3/8"

Size (mm.)
10

O.D. (In.)
0.675

O.D. (mm.)
17.1

APPLICATION AND PERFORMANCE SPECIFICATION INFORMATION IS SUBJECT TO CHANGE WITHOUT NOTIFICATION

MODEL :		TYPE
PROJECT :		
PREPARED BY :	DATE :	

ORDERING INFORMATION

Part Number: RSC037EG

Weight (lbs.): 0.09

IMS Code: 0304-8792

APPLICATION AND PERFORMANCE SPECIFICATION INFORMATION IS SUBJECT TO CHANGE WITHOUT NOTIFICATION