

MODEL :		TYPE
PROJECT :		
PREPARED BY :	DATE :	

SERIES SPECIFICATIONS

RIGID STRUT CLAMP 5"



LINE DRAWING

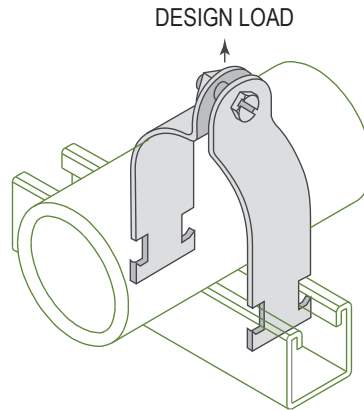

CONSTRUCTION

Type
Rigid

Design Load (Lbs.)
1000

Design Load - kN
4.45

Finish
Electro-Galvanized

DIMENSION

Size (In.)
5"

Size (mm.)
125

O.D. (In.)
5.562

O.D. (mm.)
141.3

APPLICATION AND PERFORMANCE SPECIFICATION INFORMATION IS SUBJECT TO CHANGE WITHOUT NOTIFICATION

MODEL :	TYPE
PROJECT :	
PREPARED BY :	DATE :

ORDERING INFORMATION

Part Number: RSC500EG

Weight (lbs.): 0.73

IMS Code: 0304-8813

APPLICATION AND PERFORMANCE SPECIFICATION INFORMATION IS SUBJECT TO CHANGE WITHOUT NOTIFICATION