

MODEL :		TYPE
PROJECT :		
PREPARED BY :	DATE :	

## SERIES SPECIFICATIONS

RIGID STRUT CLAMP 1-1/4"



## LINE DRAWING

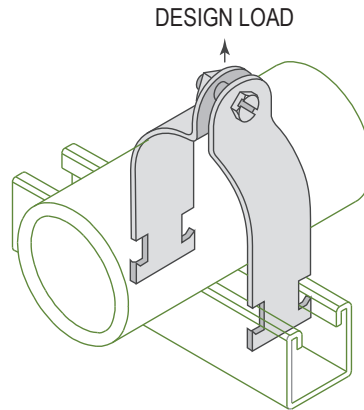

## CONSTRUCTION

Type  
Rigid

Design Load (Lbs.)  
600

Design Load - kN  
2.67

Finish  
Hot-dip Galvanized

## DIMENSION

Size (In.)  
1-1/4"

Size (mm.)  
32

O.D. (In.)  
1.66

O.D. (mm.)  
42.2

APPLICATION AND PERFORMANCE SPECIFICATION INFORMATION IS SUBJECT TO CHANGE WITHOUT NOTIFICATION

MODEL :		TYPE
PROJECT :		
PREPARED BY :	DATE :	

ORDERING INFORMATION

Part Number: RSC125HD

Weight (lbs.): 0.17

IMS Code: 0304-8933

APPLICATION AND PERFORMANCE SPECIFICATION INFORMATION IS SUBJECT TO CHANGE WITHOUT NOTIFICATION