

MODEL :		TYPE
PROJECT :		
PREPARED BY :	DATE :	

SERIES SPECIFICATIONS

RIGID STRUT CLAMP 3-1/2"



LINE DRAWING

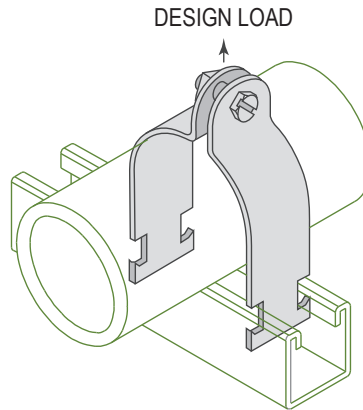

CONSTRUCTION

Type
Rigid

Design Load (Lbs.)
1000

Design Load - kN
4.45

Finish
Hot-dip Galvanized

DIMENSION

Size (In.)
3-1/2"

Size (mm.)
90

O.D. (In.)
4

O.D. (mm.)
101.6

APPLICATION AND PERFORMANCE SPECIFICATION INFORMATION IS SUBJECT TO CHANGE WITHOUT NOTIFICATION

MODEL :		TYPE
PROJECT :		
PREPARED BY :	DATE :	

ORDERING INFORMATION

Part Number: RSC350HD

Weight (lbs.): 0.57

IMS Code: 0304-8948

APPLICATION AND PERFORMANCE SPECIFICATION INFORMATION IS SUBJECT TO CHANGE WITHOUT NOTIFICATION