

MODEL :		TYPE
PROJECT :		
PREPARED BY :	DATE :	

## SERIES SPECIFICATIONS

RIGID STRUT CLAMP 2-1/2"



## LINE DRAWING

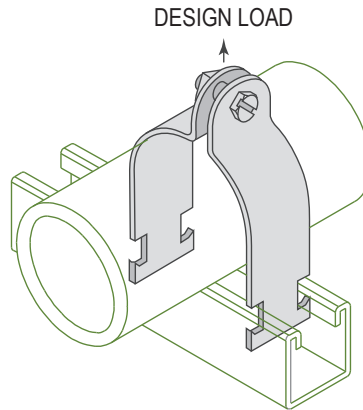

## CONSTRUCTION

Type  
Rigid

Design Load (Lbs.)  
800

Design Load - kN  
3.56

Finish  
304 stainless steel

## DIMENSION

Size (In.)  
2-1/2"

Size (mm.)  
65

O.D. (In.)  
2.875

O.D. (mm.)  
73

APPLICATION AND PERFORMANCE SPECIFICATION INFORMATION IS SUBJECT TO CHANGE WITHOUT NOTIFICATION

MODEL :	TYPE	
PROJECT :		
PREPARED BY :	DATE :	

ORDERING INFORMATION

Part Number: RSC250S4

Weight (lbs.): 0.39

IMS Code: 0304-9080

APPLICATION AND PERFORMANCE SPECIFICATION INFORMATION IS SUBJECT TO CHANGE WITHOUT NOTIFICATION