

MODEL :		TYPE
PROJECT :		
PREPARED BY :	DATE :	

SERIES SPECIFICATIONS

RIGID STRUT CLAMP 4"



LINE DRAWING

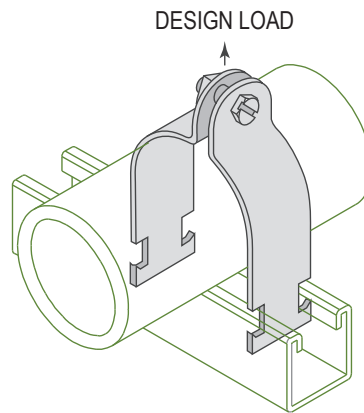

CONSTRUCTION

Type
Rigid

Design Load (Lbs.)
1000

Design Load - kN
4.45

Finish
316 stainless steel

DIMENSION

Size (In.)
4"

Size (mm.)
100

O.D. (In.)
4.5

O.D. (mm.)
114.3

APPLICATION AND PERFORMANCE SPECIFICATION INFORMATION IS SUBJECT TO CHANGE WITHOUT NOTIFICATION

MODEL :		TYPE
PROJECT :		
PREPARED BY :	DATE :	

ORDERING INFORMATION

Part Number: RSC400S6

Weight (lbs.): 0.62

IMS Code: 0304-9152

APPLICATION AND PERFORMANCE SPECIFICATION INFORMATION IS SUBJECT TO CHANGE WITHOUT NOTIFICATION