

MODEL :		TYPE
PROJECT :		
PREPARED BY :	DATE :	

## SERIES SPECIFICATIONS

RIGID STRUT CLAMP 6"



## LINE DRAWING

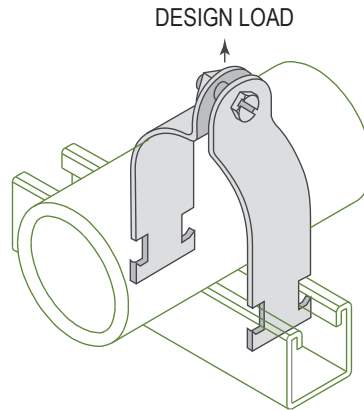

## CONSTRUCTION

Type  
Rigid

Design Load (Lbs.)  
1000

Design Load - kN  
4.45

Finish  
316 stainless steel

## DIMENSION

Size (In.)  
6"

Size (mm.)  
150

O.D. (In.)  
6.625

O.D. (mm.)  
168.3

APPLICATION AND PERFORMANCE SPECIFICATION INFORMATION IS SUBJECT TO CHANGE WITHOUT NOTIFICATION

MODEL :		TYPE
PROJECT :		
PREPARED BY :	DATE :	

ORDERING INFORMATION

Part Number: RSC600S6

Weight (lbs.): 0.85

IMS Code: 0304-9155

APPLICATION AND PERFORMANCE SPECIFICATION INFORMATION IS SUBJECT TO CHANGE WITHOUT NOTIFICATION