

MODEL :	TYPE
PROJECT :	
PREPARED BY :	DATE :

SERIES SPECIFICATIONS

1 Gang Weatherproof Twist Lock Cover



LINE DRAWING

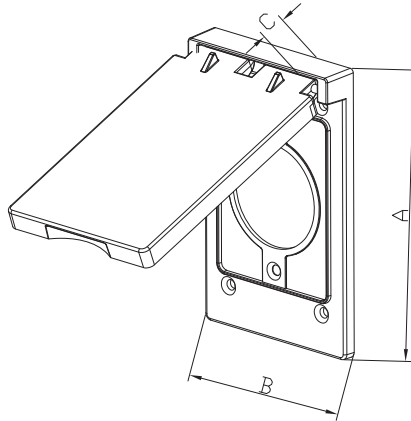

CONSTRUCTION

Material

Die Cast Zinc

Gang

1

Type

Twist Lock Cover

Finish

Gray

Screw Size

(2) 6-32UNC X 0.5 in

Amperage

50A

DIMENSION

A (In.)

4.587"

A (mm)

116.5mm

B (In.)

2.835

B (mm)

72mm

APPLICATION AND PERFORMANCE SPECIFICATION INFORMATION IS SUBJECT TO CHANGE WITHOUT NOTIFICATION

MODEL :	TYPE
PROJECT :	
PREPARED BY :	DATE :

DIMENSION

C (In.)
0.571"

C (mm)
14.5mm

ORDERING INFORMATION

Part Number: WI P018

IMS Code: 0313-4331

APPLICATION AND PERFORMANCE SPECIFICATION INFORMATION IS SUBJECT TO CHANGE WITHOUT NOTIFICATION