

CONTRACTOR	
PROJECT	DATE
PREPARED BY	MODEL : CNSQT

## SERIES SPECIFICATIONS

Channel squeeze nuts fit all US Strut support channels & wall hanger brackets. Hardened teeth from strong vise-like connection that prevents slippage. Wings fold down into channel opening. Simply insert and twist, then tighten nut, eliminating troublesome springs.



## LINE DRAWING

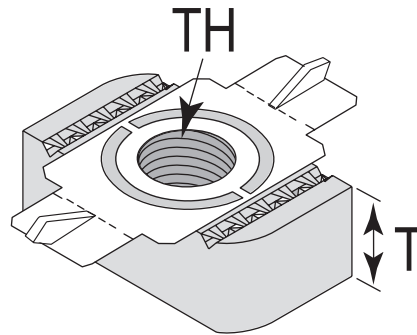

## CONSTRUCTION

**Material**

Carbon Steel

**Finish**

Electro-Galvanized

**Galvanization Material**

Zinc

**Galvanization Thickness**

0.2mil - 0.5 mil

APPLICATION AND PERFORMANCE SPECIFICATION INFORMATION IS SUBJECT TO CHANGE WITHOUT NOTIFICATION

CONTRACTOR	
PROJECT	DATE
PREPARED BY	MODEL : CNSQT

## ORDERING INFORMATION

Catalog Number	TH Size.	T In.	T mm	Wt. Lbs.	IMS Code
CNSQT2025EG	1/4" - 20	0.25	6.3	0.087	0315-2100
CNSQT3037EG	3/8" - 16	0.37	9.4	0.093	0315-2103
CNSQT3050EG	1/2" - 13	0.37	9.4	0.092	0315-2106

## NOTES

Carbon Steel – ASTM A1011-00 SS GR 33 or ASTM A1011-00CS Type B

EG – Electro-Galvanized. Electroplating deposits zinc on the surface of the steel by electrolysis from a bath of zinc salts. Recommended for relatively dry indoor use. This is the standard coating for most Phoenix products. Thickness of applied zinc is between 0.2 mils to 0.5 mils [5.1  $\mu$ m to 12.7  $\mu$ m]. Coatings on EG products meet ASTM B633 SC1 Type III.

APPLICATION AND PERFORMANCE SPECIFICATION INFORMATION IS SUBJECT TO CHANGE WITHOUT NOTIFICATION