

CONTRACTOR	
PROJECT	DATE
PREPARED BY	MODEL :

SERIES SPECIFICATIONS

2" PLUG W/PULL EYE



LINE DRAWING

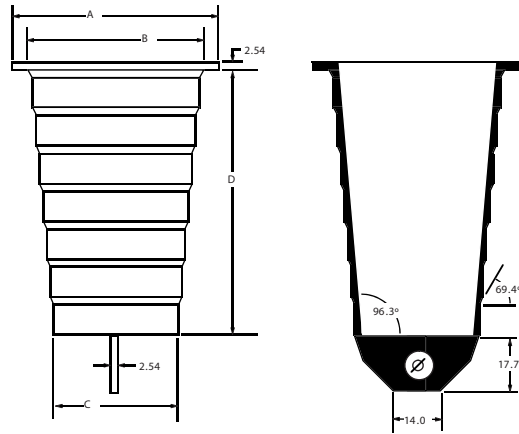

CONSTRUCTION

Size (in.)

2 - 2.5

Grosueur Size

50-65

Ø

9.2

A (mm)

80

B (mm)

66

C (mm)

47

D (mm)

89

ORDERING INFORMATION

Part Number: PLG25

APPLICATION AND PERFORMANCE SPECIFICATION INFORMATION IS SUBJECT TO CHANGE WITHOUT NOTIFICATION